

INTELLECTUAL CAPITAL AND GOOD CORPORATE GOVERNANCE STRUCTURE ON FINANCIAL PERFORMANCE AT ISLAMIC COMMERCIAL BANKS IN INDONESIA

Muhibuddin¹⁾, M. Arief Mufraini²⁾

^{1,2)} Universitas Islam Negeri Syarif Hidayatullah Jakarta

e-mail: nalar.brilliant@gmail.com ¹⁾, ariefmufraini@uinjkt.ac.id ²⁾

ABSTRACT

This research article was intended to determine the significance of the influence provided by factors on the financial performance of Islamic commercial banks, which include Intellectual Capital (IC) and Good Corporate Governance (GCG). The subjects involved in this research were Islamic banking in Indonesia which had published its 2019 financial reports. The samples in this research were determined by purposive sampling method, which was based on the criteria that had been determined in this research. Regarding to the sample selection process, there were only 13 companies that published 2019 financial statements. This research was successfully carried out by using Component Based SEM with PLS as a data processing and analysis tool. The results of this research inferred that there was a positive influence of Intellectual Capital and Good Corporate Governance Structure on the Financial Performance of Islamic Commercial Banks in Indonesia. This research provided positive implications for Islamic banks that have seriously managed good Intellectual Capital by implementing a Good Corporate Governance structure that is simultaneously able to increase the company's financial performance.

Keywords: *Intellectual Capital; Return on Assets; Financial performance.*

A. INTRODUCTION

Islamic banks are defined as highly able to contribute a strategic role in the national economy. As an intermediary institution, Islamic banks are capable of mobilizing public funds that are used to finance investment activities and provide service facilities in payment traffic under Islamic principles.¹ The Islamic banking industry has been widely growing since the enactment of Law Number 21 of 2008 concerning Islamic Banking. Therefore, Islamic banks are considered to have a strong legal basis and are able to stimulate faster economic growth. As a business entity, Islamic banks are intended to develop performance in obtaining profits, thus causing financial performance to be used as a benchmark for success in carrying out business activities. Financial performance is referred to as an overview of the company's financial condition over a certain period of time. In addition, financial performance is also able to indicate the results of many individual decisions made continuously by the management.² Financial performance is also defined as a measure of company performance. Consequently, profit is believed to be the main indicator for measuring the performance of the business entity by managers.³ Having regard to that matter, it may be inferred that financial performance is an indicator used by the company to gauge its financial achievement over a certain period with the aim of achieving the specified goals or targets.

Financial performance can typically be measured through the profitability with a Return on Assets (ROA) proxy, as used in the research conducted by Kusuma H. and Ayumardani A. (2016), Ozkan et al. (2016), and Joshi et al. (2013). Furthermore, profitability can be measured by means of two proxies, specifically Return on Assets (ROA) and Return on Equity (ROE) by Hassan et al. (2016), Setianto and Sukmana (2016), Ousama and Fatima (2015). Tandon et al. (2016) and Chen et al. (2005) through the proxies of profitability,

¹ Choirul Mahfud, "Imagined Islamic Societies and The Role of Ulema in Contemporary Indonesia," *Akademiaka: Jurnal Pemikiran Islam* 24, no. 02 (2019).

² Sucipto, *Penilaian Kinerja Keuangan. Jurnal Akuntansi* (Medan: Universitas Sumatera Utara, 2003). 1

³ James C Van Horne and Wachowicz Jr. John M, *Prinsip-Prinsip Manajemen Keuangan Edisi Kesembilan* (Simon & Schuter (Asia) Pte Ltd, 1998). 9

productivity, and market value which include Market to Book Value (M/B), Return on Assets (ROA) and Asset Turnover (ATO). Therefore, financial performance can be measured through Return on Equity (ROE), Return on Assets (ROA) and Asset Turnover (ATO).

The capability of a company is based on Intellectual Capital. Consequently, all available resources are capable of creating value added.⁴ Recognition of intellectual capital as a driver of company value and competitive advantage has been steadily increasing. According to Cheng et al., intellectual capital is referred to as a key resource and driver for company performance and value creation, so that intellectual capital is highly able to play a major role in creating and maintaining competitive advantage.⁵ If the company has provided high value added, the company should also be able to contribute high financial performance.

Information related to financial performance will be utilized for investors in the investment decision-making process. Financial performance should also reflect the company's going concern information as well as a promising rate of return to all stakeholders. In light to that matter, a good corporate governance (GCG) is highly needed in every business aspect of the company. GCG is declared as a system and structure to manage the company with the aim of increasing stakeholders' value and allocating various stakeholders such as creditors, suppliers, business associations, consumers, workers, government and the wider community.⁶ The implementation of Corporate Governance in a company will provide a significant influence on the achievement of the company's success. Corporate Governance is also functioned as a system that is capable of directing and controlling the organization.⁷ Currently, the Islamic banking

⁴ T.A. Stewart, *Intellectual Capital: The New Wealth of Organizations* (New York: Doubleday / Currency, 1997).

⁵ M Cheng et al., "Invested Resource, Competitive Intellectual Capital and Corporate Performance," *Journal of Intellectual Capital* 11, no. 4 (2010): 433–50.

⁶ Hesel Nogi. Tangkilisan, *Implementasi Kebijakan Publik* (Yogyakarta: Lukman Offset YPAPI, 2003); Choirul Mahfud, *Tantangan Global Dan Lokal Islam Di Indonesia*, ed. Alviana C (Yogyakarta: Samudra Biru, 2019).

⁷ I Nyoman Tjager and Et.al, *Corporate Governance: Tantangan Dan Kesempatan Bagi Komunitas Bisnis Indonesia* (Jakarta: Prenhallindo, 2003).

industry in Indonesia is growing since the enactment of Law Number 21 of 2008 concerning Islamic Banking, so that it has a strong legal basis and stimulates even faster growth. The growth of Islamic banking assets, financing and third-party funds in 2017 increased by 9.93%, 10.89% and 11.93%, respectively. From this growth, research on Islamic banking is interesting to do.

B. RESEARCH METHOD

This research was classified as associative research, which was intended to explain the relationship between two or more variables.⁸ The associative relationship between these variables was classified as a causal relationship. Referring to that matter, causal research is defined as a research that aims to determine the causal relationship between the variables being examined (Istijanto, 2005).

The independent variable (Intellectual Capital and the structure of Good Corporate Governance) and the dependent variable (financial performance) in this research were found to have a causal relationship. According to Sugiyono, quantitative research method is defined as a research method based on the philosophy of positivism which considers the reality/symptom/phenomenon to be classified, relatively fixed, concrete, observable, measurable, and the relationship between symptoms is causal.⁹

The population in this research was Islamic Commercial Banks in Indonesia. Moreover, samples were successfully gathered by using the purposive sampling method with the following criteria: 1) Islamic Commercial Banks that were listed from 2018 until 2019; 2) Islamic Commercial Banks that were not liquidated, acquired, and merged during 2019; and 3) Islamic Commercial Banks that had published 2019 financial statements and had complete data related to the variables used. The sample data used in this research are presented in the following table:

No	Bank Code	Bank Name
1	BAS	PT. Bank Aceh Syariah

⁸ Sugiyono, *Metode Penelitian Bisnis* (Bandung: Alfabeta, 2009).

⁹ Sugiono, *Metode Penelitian Pendidikan Pendekatan Kuantitatif, Kualitatif dan R&D* (Bandung: Alfabeta, 2013); Sugiyono, *Metode Penelitian Bisnis*.

2	BMIS	PT. Bank Muamalat Indonesia
3	BVIS	PT. Bank Victoria Syariah
4	BRIS	PT. Bank BRI Syariah
5	BJPS	PT. Bank Jabar Banten Syariah
6	BNIS	PT. Bank BNI Syariah
7	BSM	PT. Bank Syariah Mandiri
8	BSMI	PT. Bank Mega Syariah
9	BPS	PT. Bank Panin Dubai Syariah
10	BSB	PT. Bank Syariah Bukopin
11	BCAS	PT. BCA Syariah
12	BMSI	PT. Maybank Syariah Indonesia
13	BTPS	PT. Bank Tabungan Pensiunan Nasional Syariah

Data analysis in this research was carried out by means of two stages including; 1) descriptive analysis and 2) Partial Least Square (PLS) analysis).¹⁰ Descriptive analysis is defined as the process of collecting data consisting of descriptions, explanations of an object in accordance with the criteria and matters needed in data collection and presentation. Furthermore, Partial Least Square (PLS) analysis is referred to as a powerful analytical method for not based on many assumptions.¹¹ The data is not required to have a multivariate normal distribution (indicators with categorical, ordinal, interval to ratio scales can be used in the same model), and the samples are not required to be large in size. PLS analysis can be conducted through the following stages:¹²

1. Designing a structural model or inner model. The inner model is believed as a model that aims to specify the relationship between latent variables. Moreover, the inner model is also considered as a model that describes the relationship between latent variables based on substantive theory.

¹⁰ Jogianto, *Konsep Dan Aplikasi Structural Equation Modeling Berbasis Varian Dalam Penelitian Bisnis* (Yogyakarta: UPP STIM YKPN, 2011).

¹¹ Imam. Ghozali, *Struktural Equation Modeling Metode Alternatif Dengan Partial Least Square (PLS)* (Semarang: UNDIP, 2011).

¹² Jogianto, *Konsep Dan Aplikasi Structural Equation Modeling Berbasis Varian Dalam Penelitian Bisnis*.

2. Designing a measurement model or outer model. The outer model is referred to as a model that specifies the relationship between the latent variable and its indicators. In addition, the outer model is also declared capable of defining how each indicator relates to its latent variables.
3. Constructing a path diagram for each variable.
4. Converting path diagrams to equations.
5. Performing parameter estimation, specifically: (a) Weight estimate that is used to calculate latent variable data; (b) Path estimate connecting between latent variables (path coefficient) and between latent variables and their indicators (loading); (c) Regarding the means and location of parameters (regression constant values) for indicators and latent variables; (d) PLS estimation method; (e) Godness of fit, particularly for reflective outer models

The schematic diagram of the PLS research is shown as follows.

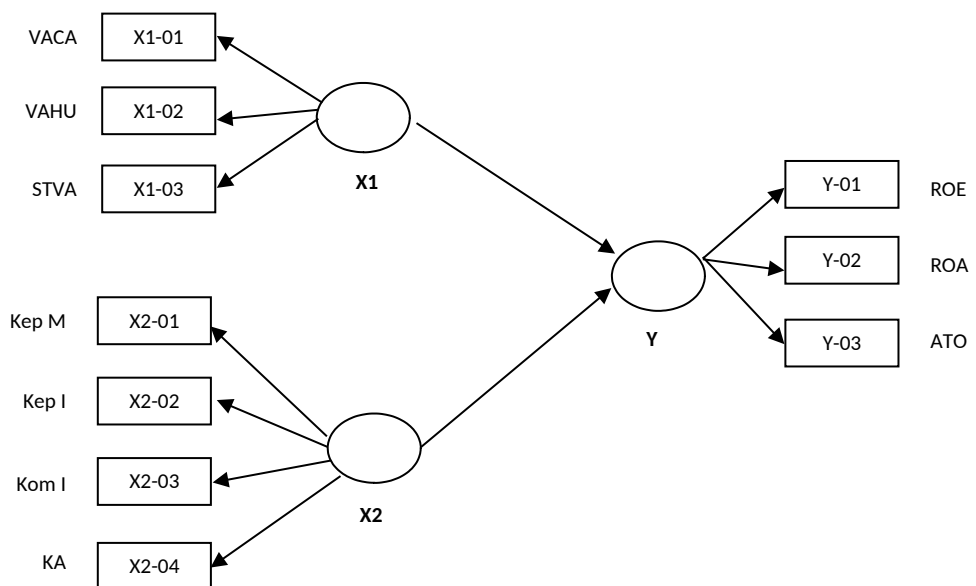

C. RESULT AND DISCUSSION

Descriptive statistics are related to the process of collecting, presenting, and summarizing various data characteristics, thus being able to describe the character of the sample used in this research,

including the 2019 data of 13 Islamic Commercial Banks in Indonesia. Variable descriptions in descriptive statistics used in this research consisted of minimum value, maximum value, mean and standard deviation of each dependent variable, particularly Intellectual Capital (X1) which includes: VACA (Value Added Capital Employed), VAHU (Value Added Human Capital), and STVA (Structural Capital Value Added), and Good Corporate Governance (GCG) Structure (X2) consisting of: Managerial Ownership, Institutional Ownership, Independent Commissioner, and Audit Committee, as well as each of the dependent variables, namely Financial Performance (Y) which includes: Return On Equity (ROE), Return On Assets (ROA), and Asset Turnover (ATO). The descriptive statistics of each variable used in this research can be seen in the following table:

No	Variable	N	Minimum	Maximum	Mean	Std. Deviation
1.	ROE	13	0.002	0.312	0.087	0.097
2.	ROA	13	0	0.136	0.026	0.043
3.	ATO	13	0.008	0.257	0.096	0.059
4.	VACA	13	0.002	0.193	0.048	0.057
5.	VAHU	13	1.021	4.875	1.651	0.997
6.	STVA	13	0.021	0.795	0.273	0.229
7.	Managerial Ownership	13	0	0	0	0
8.	Institutional Ownership	13	0.888	1	0.984	0.033
9.	Independent Commissioner	13	1	1	1	0
10.	Audit Committee	13	1	7	4.308	1.682

1. Return on Equity (ROE)

Regarding to the test results above, it was found that the lowest Return on Equity (ROE) value was amounted to 0.002 and the highest value was amounted to 0.312. These results indicated that the amount of Return on Equity (ROE) of the companies involved as the sample of this research ranged from 0.002 to 0.312 with a mean value of 0.087. The standard deviation of Return on Equity (ROE) was found to be 0.097, which indicated that the limit of deviation of the Return On Equity (ROE) variable in this research was amounted to 0.097. Having regard to this value, it may be stated that the standard deviation value was greater than the mean value. This showed that large fluctuations in Return on Equity (ROE) were found in 13 Islamic Bank companies in 2019.

2. Return on Asset (ROA)

Based on the results of the Descriptive Analysis Table test above, it was found that the lowest Return on Asset (ROA) value was amounted to 0.000 and the highest value was amounted to 0.136. These results indicated that the amount of Return on Assets (ROA) of the companies involved as the sample of this research ranged from 0.000 to 0.136 with a mean value of 0.026. The standard deviation value of liquidity was found to be 0.043, which indicated that the limit of deviation of the Return on Assets (ROA) variable in this research was amounted to 0.43. Referring to that value, it may be stated that the standard deviation value was greater than the mean value. Moreover, this showed that large fluctuations in Return on Assets (ROA) were found in 13 Islamic Bank companies in 2019.

3. Asset Turnover (ATO)

Referring to the test results of the Descriptive Analysis Table above, it was found that the Asset Turnover (ATO) value provided a minimum value of 0.008 and a maximum value of 0.257, with an average value of 0.096 and a standard deviation of 0.059. This indicated that the limit for deviation of the Asset Turnover variable (ATO) in this research was amounted to 0.059. Based on this value, it may be stated that the standard deviation value was smaller than the mean value. Moreover, this indicated that small

fluctuations in Asset Turnover (ATO) were found in 13 Islamic Bank companies in 2019.

4. Value Added Capital Employed (VACA)

Based on the results of the Descriptive Analysis Table test above, it was found that the Value-Added Capital Employed (VACA) contributed a minimum value of 0.002 and a maximum value of 1.193, with an average value of 0.048 and a standard deviation of 0.057. This indicated that the limit for the deviation of the Value Added Capital Employed (VACA) variable in this research was amounted to 0.057. Regarding to this value, it may be declared that the standard deviation value was greater than the mean value. Moreover, this showed that large fluctuations in Value Added Capital Employed (VACA) were found in 13 Islamic Bank companies in 2019.

5. Value Added Human Capital (VAHU)

In line with the results of the Descriptive Analysis Table test above, it was found that the Value-Added Human Capital (VAHU) provided a minimum value of 1.021 and a maximum value of 4.875, with an average value of 1.651 and a standard deviation of 0.997. This indicated that the deviation limit of the Value Added Human Capital (VAHU) variable in this research was amounted to 0.997. Having regard to the value, it may be defined that the standard deviation value was smaller than the mean value. This indicated that small fluctuations in Value Added Human Capital (VAHU) were found in 13 Islamic Bank companies in 2019.

6. Structural Capital Value Added (STVA)

Based on the results of the Descriptive Analysis Table test above, it was found that the Structural Capital Value Added (STVA) contributed a minimum value of 0.021 and a maximum value of 0.795, with an average value of 0.273 and a standard deviation of 0.229. This indicated that the limit for deviation of the Structural variable Capital Value Added (STVA) in this research was amounted to 0.229. Regarding to this value, it may be defined that the standard deviation value was smaller than the mean value. Moreover, this showed that small fluctuations in Structural Capital

Value Added (STVA) were found in 13 Islamic Bank companies in 2019..

7. Managerial Ownership

Based on the test results in the Table of Descriptive Analysis above, it was known that the Managerial Ownership provided a minimum value of 0.000 and a maximum value of 0.000, with an average value of 0.000 and a standard deviation of 0.000. This indicated that the limit for the deviation of the Managerial Ownership variable in this research could not be found due to constant results. Regarding to this value, Managerial Ownership cannot be measured in 13 Islamic Bank companies in 2019.

8. Institutional Ownership

Referring to the test results of the Descriptive Analysis Table above, it was found that the Institutional Ownership provided a minimum value of 0.888 and a maximum value of 1,000, with an average value of 0.984 and a standard deviation of 0.033. This indicated that the limit of deviation of the Institutional Ownership variable in this research was amounted to 0.033. In light of this value it may be stated that the standard deviation value was smaller than the mean value. This showed that small fluctuations in Institutional Ownership were found in 13 Islamic Bank companies in 2019

9. Independent Commissioners

Regarding to the test results of the Descriptive Analysis Table above, it was found that the Independent Commissioners provided a minimum value of 1.000 and a maximum value of 1.000, with an average value of 1.000 and a standard deviation of 1.000. This indicated that the limit for deviation of the Independent Commissioner variable in this research could not be measured due to constant results. In line with that value, it may be stated that the standard deviation value was equal to the mean value. Moreover, this showed that fluctuations in the Independent Commissioners cannot be measured in 13 Islamic Bank companies in 2019.

10. Audit Committee

Based on the results of the Descriptive Analysis Table test above, it was known that the Audit Committee contributed a minimum

value of 1.000 and a maximum value of 7.000, with an average value of 4.308 and a standard deviation of 1.682. This indicated that the deviation limit of the Audit Committee variable in this research was amounted to 1.682. Referring to this value, it may be inferred that the standard deviation value was smaller than the mean value. Moreover, this indicated that small fluctuations in the Audit Committee were found in 13 Islamic Bank companies in 2019.

1. The Influence of Intellectual Capital on Financial Performance

Having regard to the results of the t test table, it was found that Intellectual Capital provided a significant positive effect on financial performance, it may be viewed from the t statistic of 7.430 which showed that the t_{count} value of 7.430 > t_{table} value of 1.771. Furthermore, by referring to the probability level of 0.000, it was indicated that the probability value of Intellectual Capital < the value of $\alpha = 5\%$. Therefore, H1 was accepted and H0 was rejected. The significant positive effect was amounted to 0.815, which was indicated by each score of Intellectual Capital, which had increased by one standard deviation. Therefore, the value of financial performance would increase with a standard deviation of 0.815, assuming the others were constant.

Referring to previous research that supports the hypothesis of the influence of IC on financial performance conducted by Kamini Tandon, Harsh Purohit, Deepak Tandon (2016) with the title: Measuring Intellectual Capital and Its Impact on Financial Performance: Empirical Evidence from CNX Nifty Companies, there was a positive relationship between VAIC and all measures of financial performance-profitability, productivity and market valuations. By using the panel data regression method on 50 publicly traded companies in India, Kamini Tandon et al. concluded that the IC provided a significant role on financial performance. In addition, Rahmat Heru Setianto, Raditya Sukmana (2016) who researched about Intellectual Capital and Islamic Banks' Performance; Evidence from Indonesia and Malaysia by

using the t-test method and Ordinary least squares (OLS) regression concluded that the VAICTM of Islamic banks in Malaysia was better than in Indonesia. Better human capital efficiency was likely able to show a higher level of profitability, and structural capital was not related to the performance of Islamic banks and capital efficiency tended to show a higher level of profitability. Nasif Ozkan, Sinan Cakan, Murad Kayacan (2016) also had successfully conducted similar research on 44 banks operating in Turkey by utilizing the panel data regression method. The conclusions of this research are found to support the hypothesis that there is an influence of IC on financial performance, because the results of the research showed that the efficiency of capital used (CEE) and efficiency of human capital (HCE) positively affected the financial performance of banks. Furthermore, research conducted by A.A. Ousama, A.H. Fatima (2015) entitled Intellectual capital and financial performance of Islamic banks by using the Ordinary least squares (OLS) regressions method indicated that the overall efficiency of Islamic Bank's Intellectual Capital was higher than conventional banks. Finally, this research concluded that intellectual capital simultaneously affected financial performance (ROA and ROE). This research had been successfully carried out with samples consisting of Islamic banks in Malaysia and by using the Ordinary least squares (OLS) regressions method which provided the results that support the hypothesis of the influence of IC on financial performance.

In research conducted by Muhammad Khaliq, Jamal Abdul Nassir bin Shaari, Abu Hassan bin Md. Isa, Noridah Binti Samad (2013) entitled Impact of Intellectual Capital on the Organizational Performance of Islamic Banking Sector in Malaysia with samples comprised of 120 employees in Islamic bank operating in Kuala Lumpur, Malaysia and by using the Multiple linear regression method, it was found that intellectual capital provided a significant influence on financial performance. Therefore, the results of this research also support the hypothesis of the influence of IC on financial performance. In another research conducted by Ya-Hui

Ling (2011) entitled *The Influence of Intellectual Capital on Organizational Performance—Knowledge Management as Moderator*, which was conducted on 146 people in the top public companies published by *CommonWealth Magazine* by using Multiple linear regression, it was concluded that intellectual capital positively related to the company's global performance. Although the moderating variable did not provide any significant impact on the company's global performance, this research strongly supports the hypothesis of the influence of IC on financial performance. Another previous research conducted by Ming-Chin Chen, Shu-Ju Cheng, Yuhchang Hwang (2005) with the title: *An Empirical Investigation Of The Relationship Between Intellectuals* which examined several public companies in Taiwan by using panel data regression method indicated that the intellectual capital of companies contributed positive impact on market value and financial performance, thus this research declared results that also support the hypothesis that there is an influence of Intellectual Capital on financial performance.

Intellectual Capital is commonly defined as intangible assets owned by companies that are able to provide added value. Consequently, if intellectual capital is able to be utilized accordingly, it can completely provide benefits to the company, including financial performance. Moreover, financial performance can also be significantly improved, if the resources that drive the main functions in the company are capable of working optimally, so that Intellectual Capital will succeed in contributing to a strategic role.

According to Cheng et al. (2010), Intellectual Capital is defined as the key resource and driver of the company's performance and value creation. Therefore, Intellectual Capital contributes to an important role in creating and maintaining competitive advantage. In this specific matter, Intellectual Capital is empirically able to drive competitive advantages that are explicitly visible, specifically financial performance. Furthermore, Bontis (2000) also revealed that Intellectual Capital will provide a

new resource for organizations to compete and win, so that the resources owned by the company can improve the financial performance. This is in line with Stewart (1997), Curado and Bontis (2009), and Sharabati et al. (2010) who defined intellectual capital as “Packaged Useful Knowledge”, which refers to knowledge resources that are able to produce high-value assets and future economic benefits for the company.

2. The Influence of Good Corporate Governance Structure on Financial Performance

Referring to the results of the t test table, it was found that the structure of Good Corporate Governance had a positive but not significant effect on financial performance, it can be seen from the t statistic of 0.083 which indicated that the t_{count} value of $0.083 < t_{\text{table}}$ value of 1.771. It can also be viewed from the probability level of 0.590, which indicated that the probability value of the Good Corporate Governance structure $>$ the value of $\alpha = 5\%$. Therefore, H_2 was rejected and H_0 was accepted. The results showed a positive but weak effect which was amounted to 0.083 for each score of Good Corporate Governance Structure.

Regarding to the structure of GCG, Kusuma H., Ayumardani A. (2016) in their research entitled The Corporate Governance Efficiency and Islamic Bank Performance: An Indonesian Evidence on 11 Islamic Banks in Indonesia by using the panel data regression method concluded that GCG efficiency had a significant effect on financial performance. Consequently, the results of this research do not support the hypothesis of the influence of GCG on financial performance. Moreover, Siti Nuryanah, Sardar M. N. Islam (2011) conducted research on 138 public companies in Indonesia by using the panel data regression method entitled Corporate Governance and Performance: Evidence From An Emerging Market. This research concluded that all internal mechanisms, except the Board of commissioners' size, Size of audit committee, and Insider ownership, provided a significant influence in explaining company performance. Therefore, the results of this research were found to support the hypothesis of the

influence of GCG on financial performance.

In general, Islamic banks have implemented 5 principles of Corporate Governance implementation as explained by the National Committee on Governance Policy (2012). This implies that the company has complied with these principles. The implementation of GCG has also been reported annually by each Islamic Bank, thus the company is trying to make the best possible announcement regarding to the structure and management of GCG. A good GCG structure is defined as an inherent component of the company, whether its financial performance is increasing or decreasing.

The current Good Corporate Governance structure has been managed accordingly, so that the decline and increase in financial performance are not directly influenced by the adequate Good Corporate Governance structure in 13 Islamic Commercial Banks. This can also be found from the exclusion of the Independent Commissioner indicator in this research which was empirically constant in value and indicated that all companies had implemented their commissioners independently (not tied to the company). In line with this, the Managerial Ownership indicator was also excluded in the research because it provided a nearly constant value which indicated that all companies did not have managerial ownership except for Bank BCA Syariah with a small portion of 0.00015%.

3. The Influence of Intellectual Capital and Good Corporate Governance Structure on Financial Performance

The results of the calculation on the statistical value of the F test showed that the F_{count} value was greater than the F_{table} value ($F = 13.382 > 3.316$). Therefore, H_0 was rejected and H_3 was accepted. Having regard to this result, it may be inferred that Intellectual Capital and Good Corporate Governance Structure contributed a positive influence on Financial Performance. The influence model of the independent latent variable of Intellectual Capital and Good Corporate Governance Structure (X_1, X_2) on Y (Financial

Performance) provided the R-square value which was amounted to 0.728. Consequently, it may be interpreted that the variability of the Y construct (Financial Performance) which could be explained by Intellectual Capital and Good Corporate Governance Structure was amounted to 72.8% while the remaining 27.29% was explained by other variables outside the research.

Good Intellectual Capital that can be driven by a good Good Corporate Governance structure will simultaneously improve the company's financial performance. The GCG structure can also support the implementation of the empowerment of each potential resource in the company which results in increasing financial performance, as explained by Jensen and Meckling (1976), that Corporate Governance is the principle that directs and controls the company in order to achieve a balance between the power and authority of the company in provide accountability to special shareholders and general stakeholders.

Corporate governance is defined as a set of systems that aim to mobilize and control the company (OECD, 2004). Referring to that matter, adequate governance and the ability to encourage existing resources within the company will subsequently be able to develop intellectual capital and have implications for increasing financial performance.

D. CONCLUSION

Intellectual Capital is commonly defined as intangible assets owned by companies that are able to provide added value. Consequently, if intellectual capital is able to be utilized accordingly, it can completely provide benefits to the company, including financial performance. Moreover, financial performance can also be significantly improved, if the resources that drive the main functions in the company are capable of working optimally, so that Intellectual Capital will succeed in contributing to a strategic role. Intellectual Capital provided a significant positive effect on the Financial Performance of Islamic Commercial Banks in Indonesia. The significant positive effect was amounted to 0.815, which was indicated by each score of Intellectual Capital, which had increased

by one standard deviation. Therefore, the value of financial performance would increase with a standard deviation of 0.815.

In general, Islamic banks have implemented 5 principles of Corporate Governance implementation as explained by the National Committee on Governance Policy (2012). This implies that the company has complied with these principles. The implementation of GCG has also been reported annually by each Islamic Bank, thus the company is trying to make the best possible announcement regarding to the structure and management of GCG. A good GCG structure is defined as an inherent component of the company, whether its financial performance is increasing or decreasing.

BIBLIOGRAPHY

- Cheng, M, J Lin, T Hsiao, and T. W. Lin. "Invested Resource, Competitive Intellectual Capital and Corporate Performance." *Journal of Intellectual Capital* 11, no. 4 (2010): 433–50.
- Ghozali, Imam. *Struktural Equation Modeling Metode Alternatif Dengan Partial Least Square (PLS)*. Semarang: UNDIP, 2011.
- Horne, James C Van, and Wachowicz Jr. John M. *Prinsip-Prinsip Manajemen Keuangan Edisi Kesembilan*. Simon & Schuter (Asia) Pte Ltd, 1998.
- Jogianto. *Konsep Dan Aplikasi Structural Equation Modeling Berbasis Varian Dalam Penelitian Bisnis*. Yogyakarta: UPP STIM YKPN, 2011.
- Kholid, M. "Praktik Akad Pembiayaan Gadai Emas Perspektif Hukum Islam." *Al-Insyiroh: Jurnal Studi Keislaman* 2.1 (2018): 128-137.
- Mahfud, Choirul. "Imagined Islamic Societies and The Role of Ulema in Contemporary Indonesia." *Akademiaka: Jurnal Pemikiran Islam* 24, no. 02 (2019).
- Mahfud, Choirul. *Tantangan Global Dan Lokal Islam Di Indonesia*. Edited by Alviana C. Yogyakarta: Samudra Biru, 2019.
- Mashudi, Mashudi. "Perilaku Dan Budaya Konsumen Madura Dalam Dinamika Etika Bisnis Syariah." *Al-Insyiroh: Jurnal Studi Keislaman* 2.2 (2018): 133-149.
- Muttaqin, Imamul. "Konsep Al-Kasb Dan Modernisasi Islam." *Al-Insyiroh: Jurnal Studi Keislaman* 1.1 (2015): 23-43.
- Stewart, T.A. *Intellectual Capital: The New Wealth of Organizations*. New York: Doubleday / Currency, 1997.
- Sucipto. *Penilaian Kinerja Keuangan. Jurnal Akuntansi*. Medan: Universitas Sumatera Utara, 2003.
- Sugiono. *Metode Penelitian Pendidikan Pendekatan Kuantitatif, Kualitatif dan R&D*. Bandung: Alfabeta, 2013.
- Sugiyono. *Metode Penelitian Bisnis*. Bandung: Alfabeta, 2009.
- Suparyanto, Didik. "Prospek Perbankan Syariah di Indonesia." *Al-Insyiroh: Jurnal Studi Keislaman* 2.2 (2018): 170-181.
- Tangkilisan, Hesel Nogi. *Implementasi Kebijakan Publik*. Yogyakarta: Lukman Offset YPAPI, 2003.
- Tjager, I Nyoman, and Et.al. *Corporate Governance: Tantangan Dan*
-

Kesempatan Bagi Komunitas Bisnis Indonesia. Jakarta: Prenhallindo, 2003.